

BATTERY-POWERED LED LAMPSHADE

Instructions manual

Please read the manual before your first use. Keep this manual safe for future reference!

WARNINGS

1. Install the lamp (lampshade installed on the bottle) on a stable surface, away from any inflammable materials and sources of heat.
2. Keep away from direct sunlight, humidity, high temperature, water or other liquids.
3. Do not immerse in water or any other liquids.
4. Do not cover the lamp when it is on.
5. Do not touch the lampshade when it is on for it could be hot.
6. Do not stare at the luminous source.
7. Disconnect it from USB connector after completion charge.
8. Do not touch with wet hands.
9. In case of abnormalities (bulge, heat, etc.) during charging, disconnect USB connector and stop using it. Do not attempt to repair the device. All repairs should be carried out by a qualified electrician.
10. Do not short-circuit, modify, disassemble or puncture it.
11. Handle the lamp with care. Any impact, shock, or fall, even from a low height, may damage it.
12. The lampshade is not a toy. Keep it out of reach of children and pets.

PRODUCT DESCRIPTION

The LED lampshade is to be affixed over one wine bottle to create the perfect atmosphere for a sought-after decorative touch to your room or when you receive your guests. PLEASE NOTE: the bottle is NOT included.

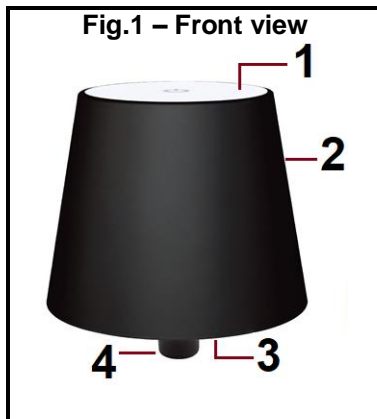

1. Button ON – OFF
2. Lampshade
3. USB charging port
4. Rod to be inserted in the neck of the bottle.

Accessory: 1 x USB cable (included)

TECHNICAL SPECIFICATIONS

Table lamp:

- Input (Charging) : 5 V 600MA 3W
- Battery: Lithium-ion (18650), 1200mAh, 3,7V
- LED (warm light): 27pcs on bottom of the lamp and 4pcs on top, each LED: 3V, 26lum, 0.2W.

BATTERY CHARGING

CHARGING TIME FOR A FULL CHARGE : About 4H/ 5H

Attention : Don't charge more than 5 hours otherwise it may damage the battery.

The lamp is delivered precharged and is normally ready for use. However, if it needs to be recharged and for future charges, follow these steps:



Connect the LED lamp to a USB port of a computer, Powerbank (5V 1A max) or removable adapter (5V 1A max) with the supplied charging cable.

Remarks

- To preserve your battery, charge the battery when the light intensity becomes weak and charge it to its maximum capacity.
- Charging it at least once a month will extend the life of the battery.
- If it has not been used for a long time, please fully charge it before use.
- The lamp contains built-in LEDs which are not replaceable.

OPERATION

The LED lampshade has only warm light.

1. Place the lampshade installed on the bottle on a flat, stable and non-slip surface.
2. Tap on the ON/ OFF button , on the top.
3. Long press the ON/ OFF  reduce the light intensity. Long press again to increase it.
4. Tap again  to turn off;

SAFETY INSTRUCTIONS CONCERNING THE BATTERY

ATTENTION

- Lithium-ion batteries can easily rupture, ignite, or explode when exposed to high temperatures, or direct sunlight.
- Do not disassemble or modify the battery. The battery contains safety and protection devices, which, if damaged, may cause the battery to generate heat, explode or ignite.
- The battery should not be removed until it is not completely discharged.
- The battery must be removed from the appliance before it is scrapped.
- The appliance must be disconnected from USB port when removing the battery.
- Do not plug the device after removing the battery.
- The battery must be disposed safely.

To access the battery, proceed as below:

1. Unscrew the 3 screws.
2. Remove the bottom cover.
3. Under the bottom cover, you will find the rechargeable battery. Cut the wires and remove the battery.

CLEANING AND MAINTENANCE

- DO NOT IMMERSE IN WATER OR ANY OTHER LIQUID.
- DO NOT USE HARSH CHEMICALS OR ABRASIVE DETERGENTS.

- Before cleaning the lampshade, if you have just used it, unplug the USB cable and allow it to cool down for 10 minutes
- Clean the lamp with a soft, dry, lint-free cloth.

STORAGE: Keep the lamp in a shady, dry and ventilated place.



WARNING: You should not dispose of this device with your household waste. A selective collection system for this type of product is implemented by your local authorities. Please contact your local authorities to find out how and where collection takes place. These restrictions apply because electrical and electronic devices contain dangerous substances that have harmful effects on the environment or on human health and must be recycled.

This symbol indicates that electrical and electronic devices are collected selectively. The symbol shows a waste container crossed out with an X symbol.

Imported by EML – PRODIS 1 rue de Rome 93110 Rosny-sous-Bois-France/ Made in P.R.C.
Marketed by EUROTUPS VERSAND GMBH D-40764 LANGENFELD, Germany

